

INSTALLATION MANUAL

For the most current release of this manual,
please visit our website at cogan.com

V.2015.1

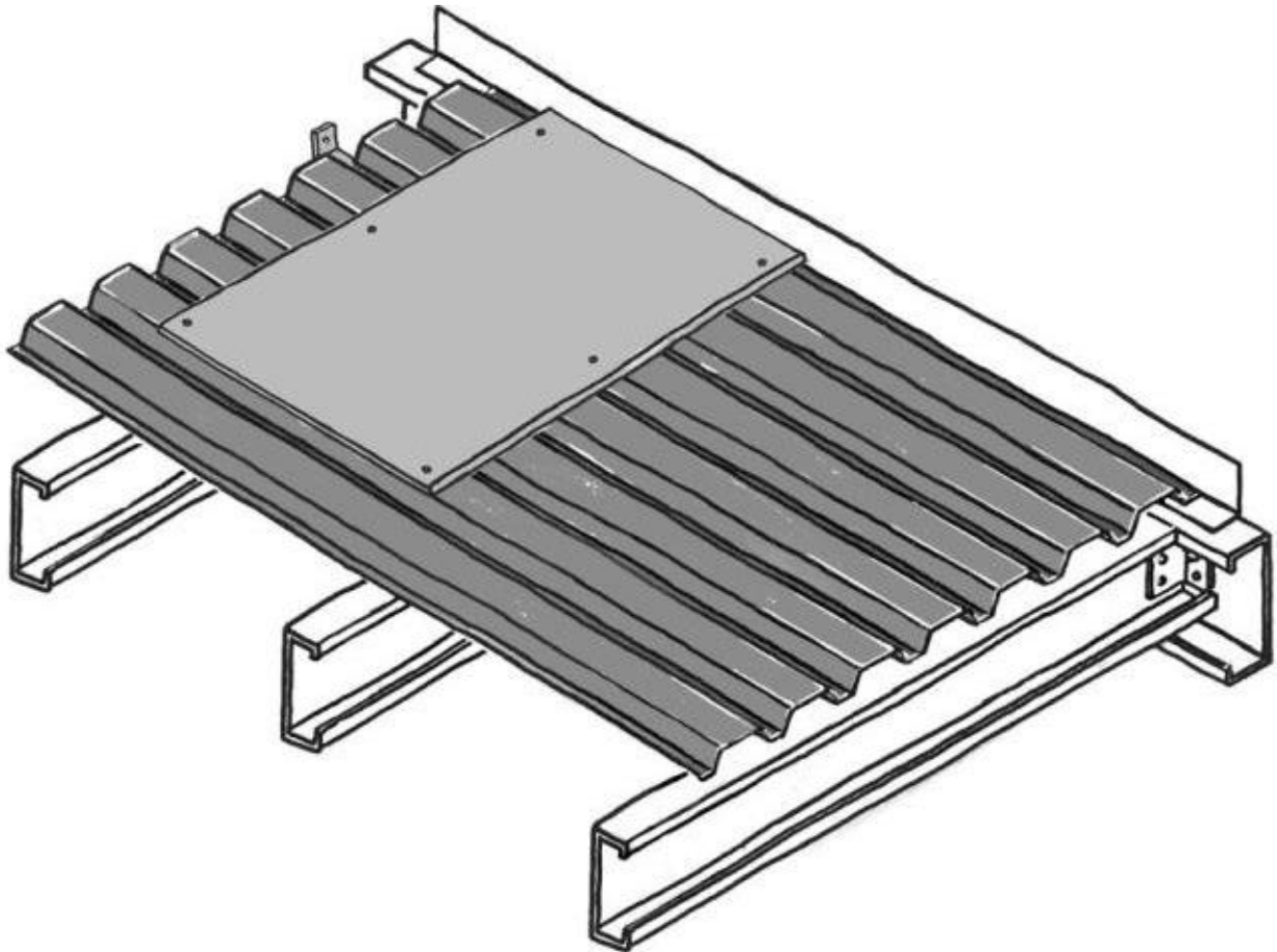

Product	Pre-Engineered Floor Decking System
Sub-product	Steel Decking and Resin

- Step by step installation of corrugated steel decking and resin.
- Refer to installation drawings for orientation of flooring

 **Cogan**[®]

A Tradition of Quality Since 1901

cogan.com



Ø1/4"x1" HEX
HEAD TEK SCREW



Ø1/4"x1 3/4" HEX
HEAD TEK SCREW

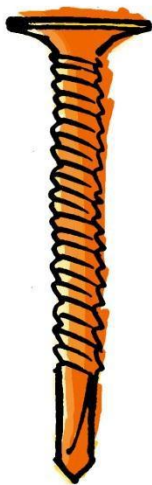

Ø1/4"x4" FLAT
HEAD TEK SCREW



Ø1/4"x2" FLAT
HEAD TEK SCREW

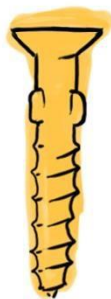

RESIN-DECK APPROVED
WOOD SCREW

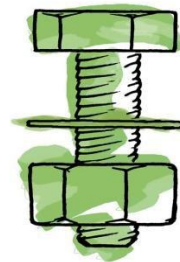

Ø5/16"x1" BOLT

STEP 1

STEEL DECK (ROOF DECK)



For all types of flooring notching and fitting may occur

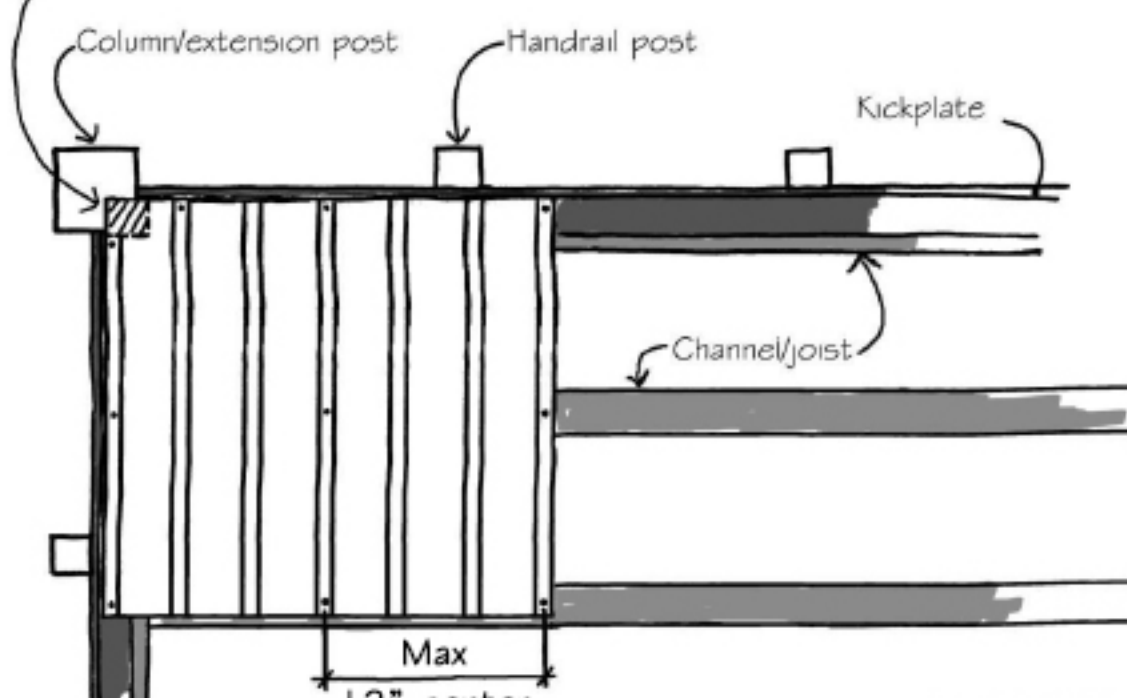

Max
12" center

(36/4 pattern unless otherwise specified in install manual.)

TOP VIEW

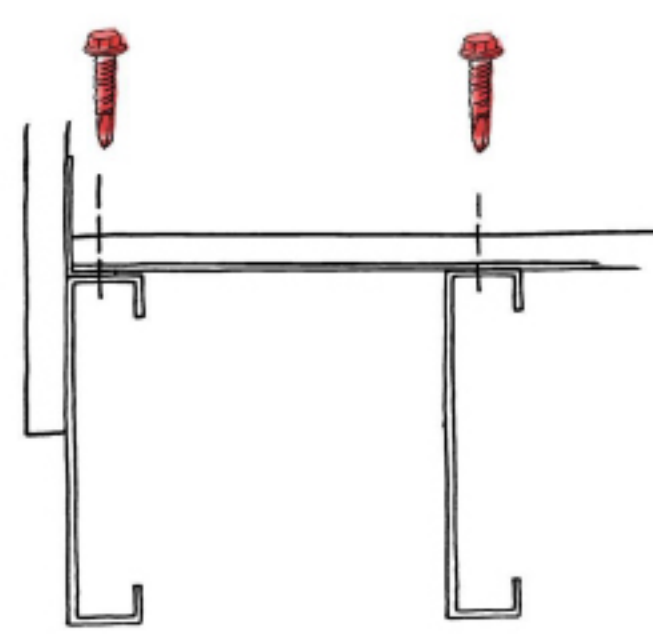

SIDE VIEW

Before starting, always refer to the install plans for your project. For any additional requirements detailed specifically for your project. Install roof deck panels starting with row 1. Always begin from edge of a channel or wall. Check on your installation drawings to know where to put the first panel and the length of it. Continue with row 2 and fix it side by side with an overlap all along the panel.

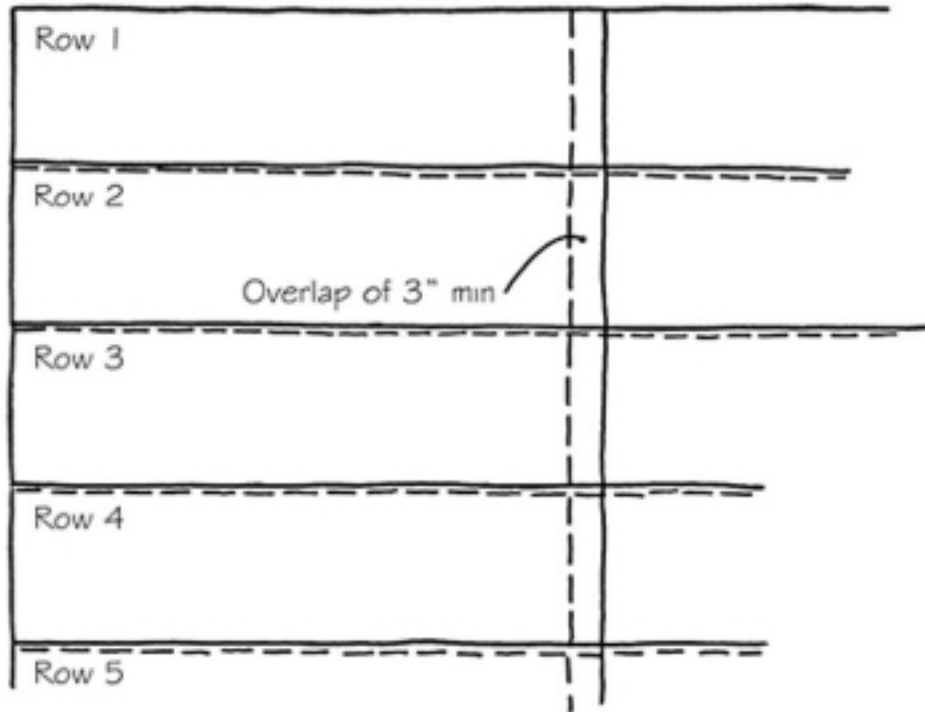

In order to prevent joist rotation, steel deck must be screwed on all joist at 12" max. distance
Or as indicated on the install plans

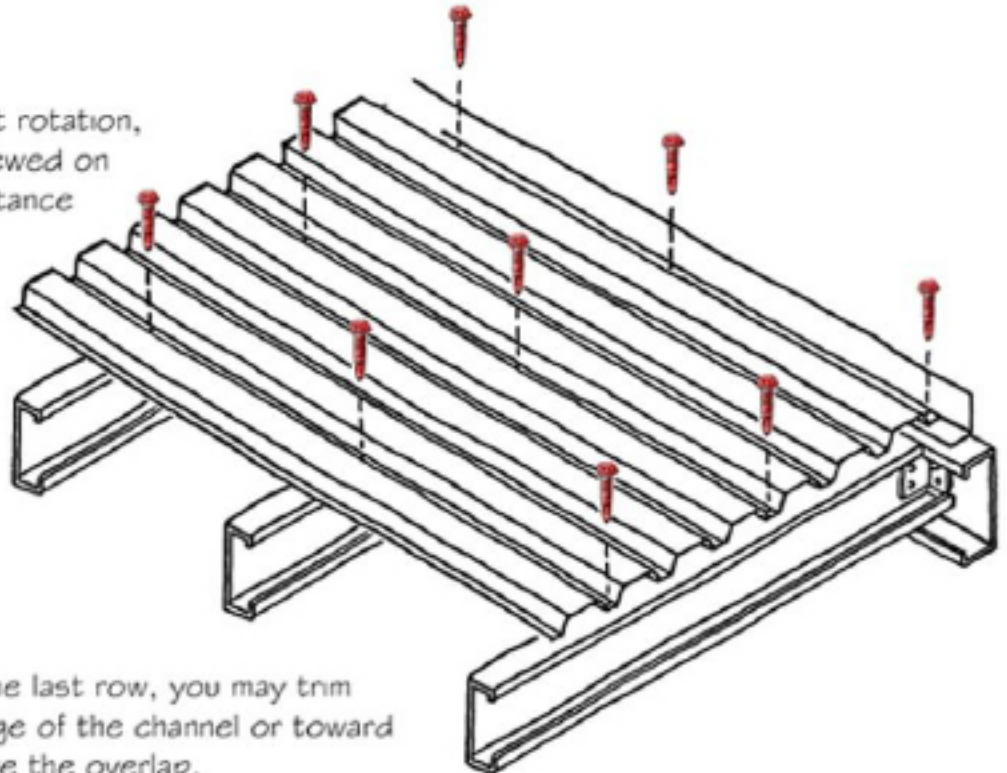

Once you've reached the last row, you may trim the roof deck along edge of the channel or toward the wall or you may leave the overlap.

STEP 2

FLOORING (COMPOSITE RESIN BOARD)



Cutting and fitting for composite deck is done by installer

VERY IMPORTANT

ALWAYS leave 3/8" gap between walls and edges of panels around the perimeter of the Pre-Engineered Floor Decking System. Leave 1/8" gap between each row

IF YOU DO NOT FOLLOW THESE INSTRUCTION, THE FLOORING WILL BUCKLE

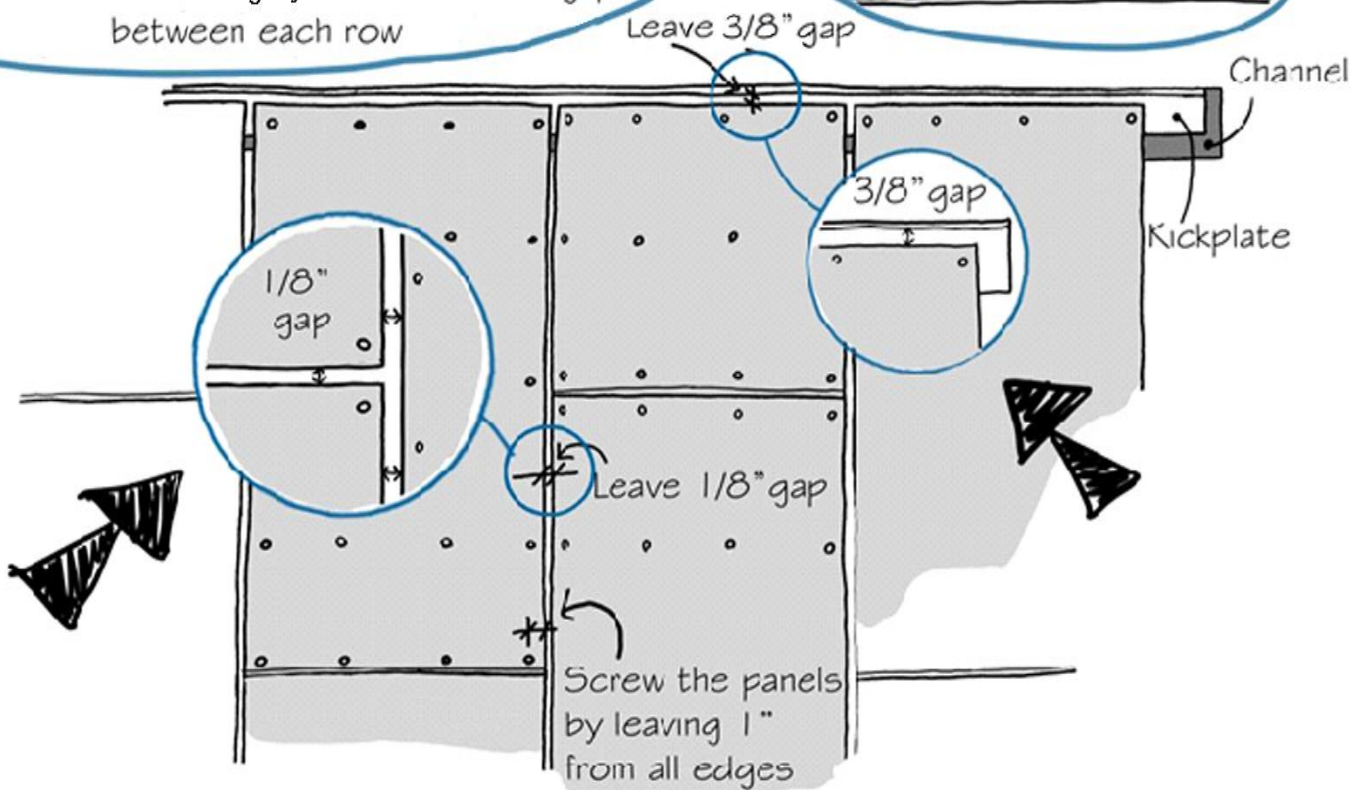

Approved screw must be placed just below the panel surface (A). Do not place approved screws too low (B) or too high (C) in the panels

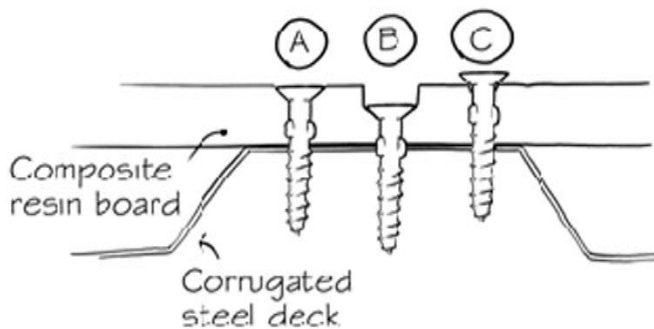



Try to always lay panels perpendicular to steel deck

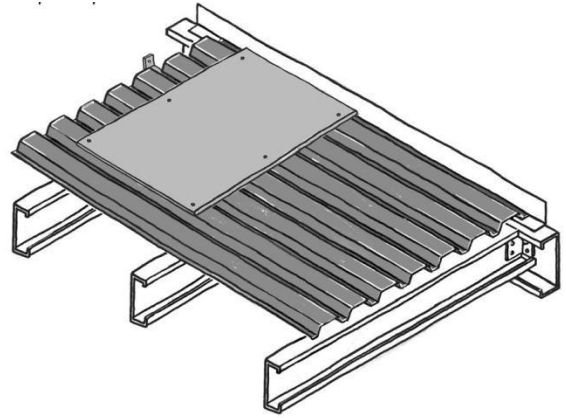

Use approved ResinDek wood screw only (screw at every 18")

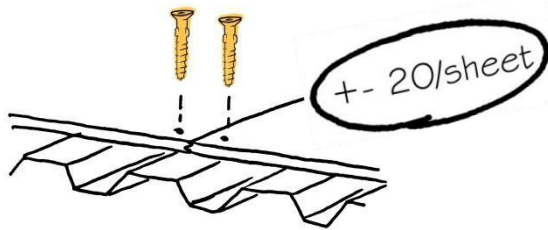

Composite resin board

Stagger panels so that joints break on different ribs. 48" x 6" x 20 gauge min. steel shims are used if joints break on a valley.

*** COGAN SUPPLIES LIMITED AMOUNT OF SHIMS PER PROJECT.**

Keep them for future projects if you do not use them all. If you require more, contact Cogan at 1-800-567-2642.

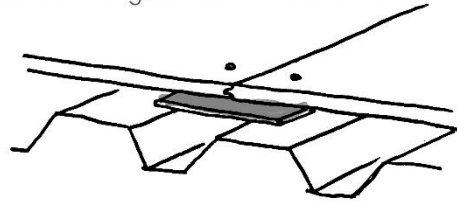

DECKING MUST BE NOTCHED ON SITE FOR ALL POST EXTENSIONS.

1/8" (MIN.) GAP REQUIRED BETWEEN PANELS

IT IS PREFERRED TO ORIENT THE RESINDEK PANELS LENGTHWISE PERPENDICULAR TO THE CORRUGATED DECK.

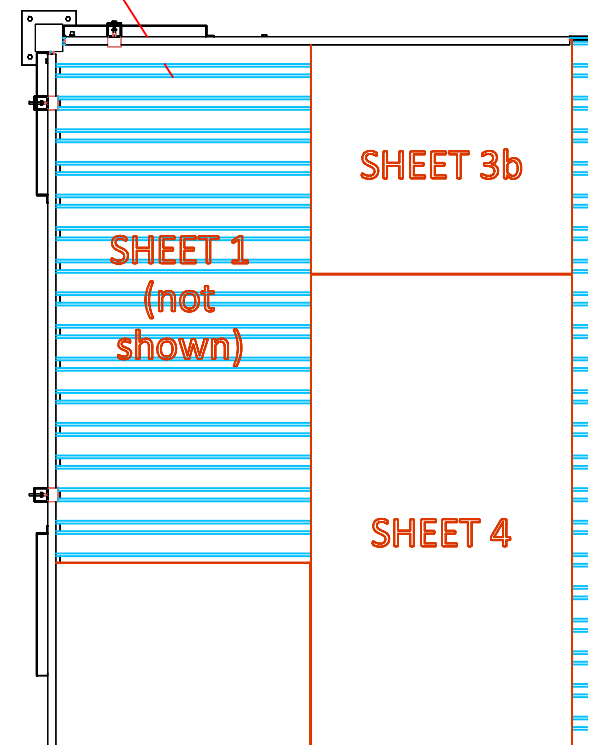
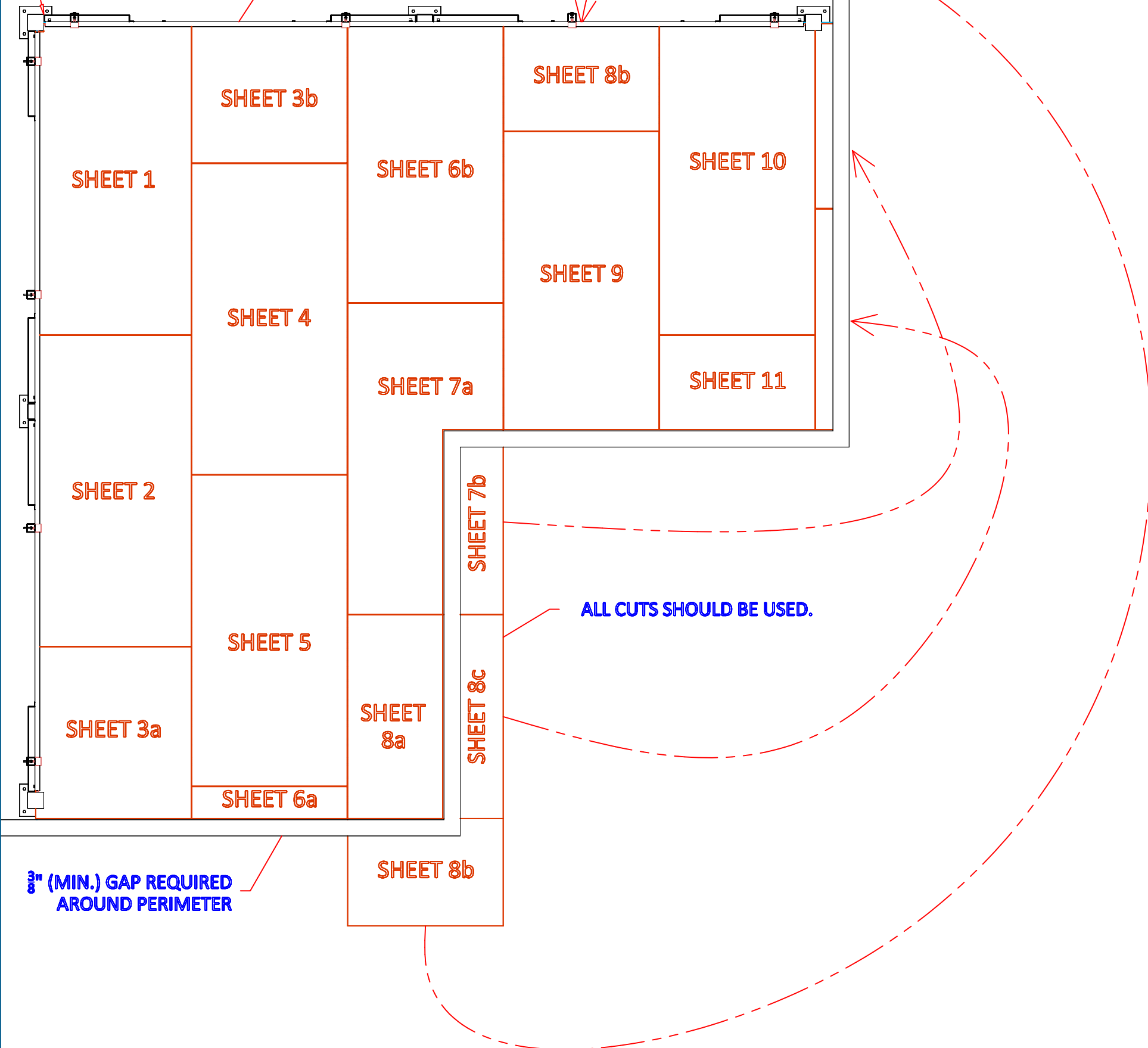

3/8" (MIN.) GAP REQUIRED AROUND PERIMETER

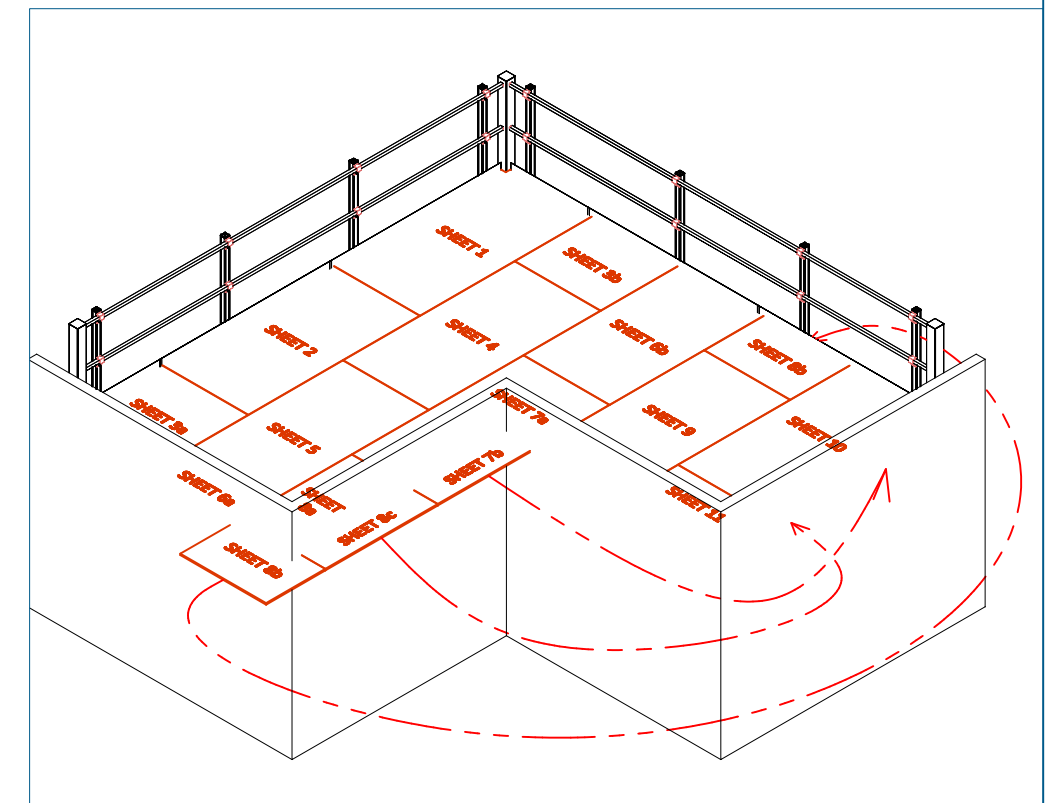

STEP 3

WALL BRACKET

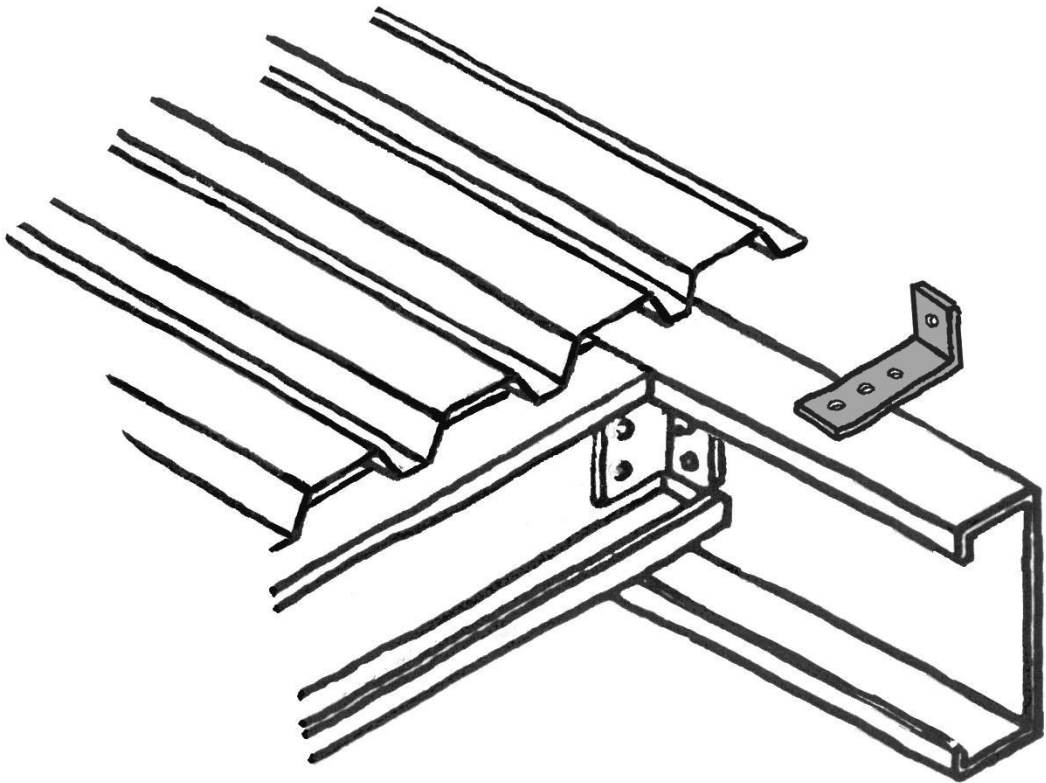
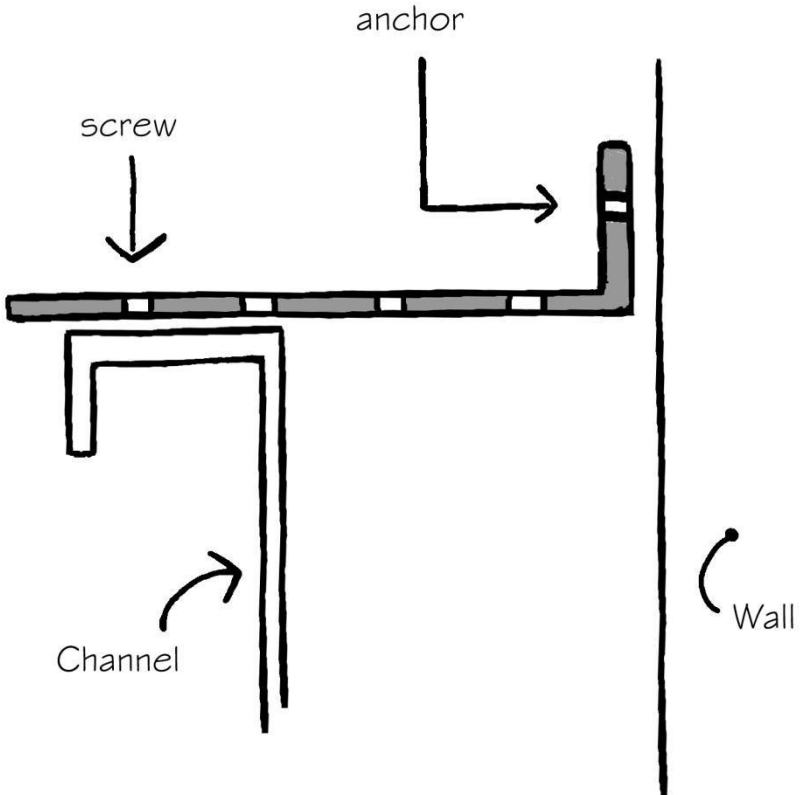

OPTIONAL

OPTIONAL PART (LOADING PLATE)



Install the loading plate at gate opening (swing, sliding pr lift-out). To attach, tek screw to the flooring along the edge of loading plate.
THE LOADING PLATE IS SIZED TO MATCH THE OPENING, NO ADJUSTMENT REQUIRED

